

7. ELEKTRISCHE INSTALLATIES

7.1 12 V/230 V installatie (CERS 20M)

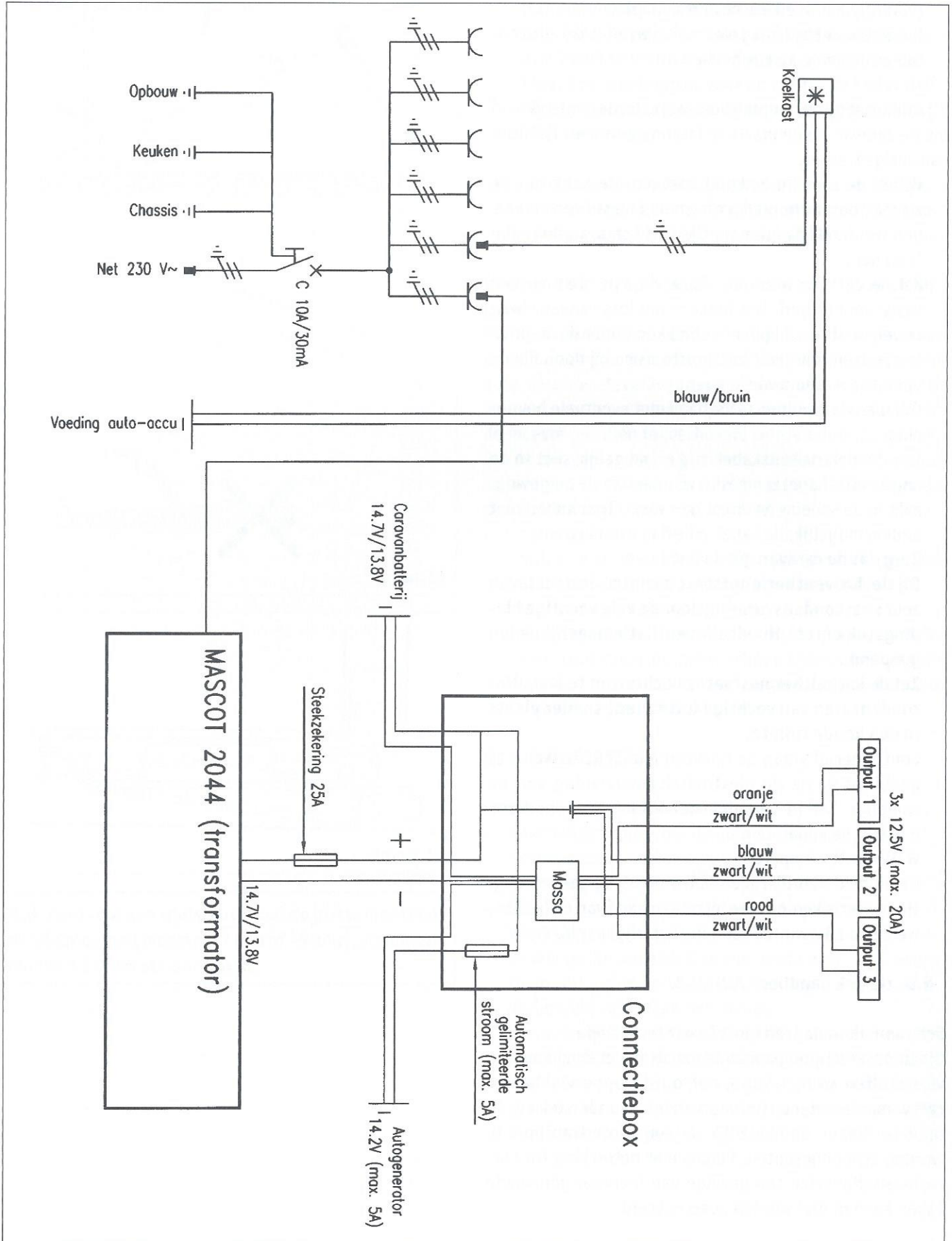

7.2 12 V/230 V installatie (CERS 30D)

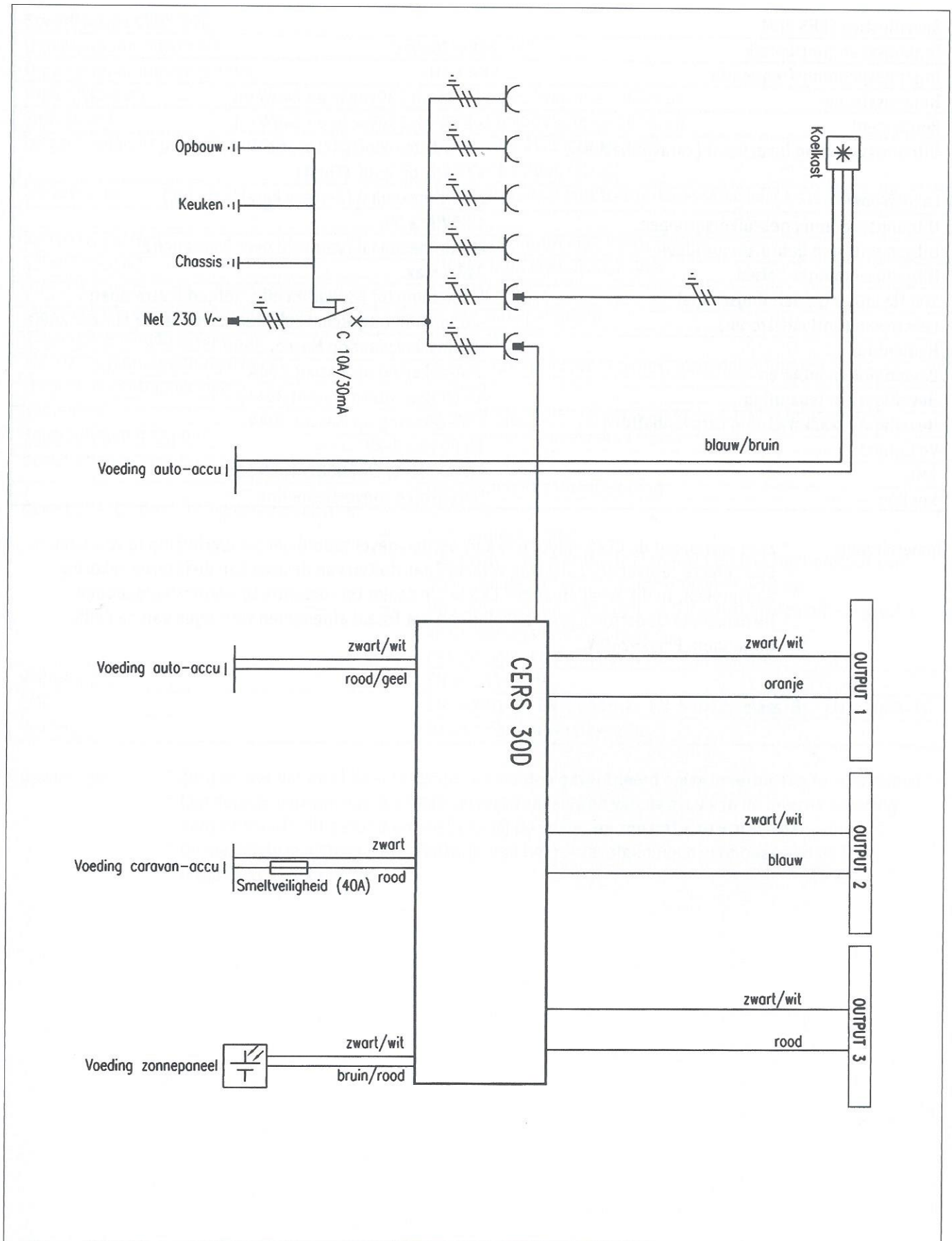

7.3 Specificaties CERS 20M

| Specificaties CERS 20M | |
|--|--|
| Ingangsspanningsbereik | 198-264Vac" |
| Ingangsspanningsfrequentie | 47-63Hz |
| Ingangsstroom | ≤ 1.3A bij 230Vac in en 240W uit |
| Rendement | ≥ 83% bij 230Vac in en 240W uit |
| Uitgangsspanning laadcircuit (caravanbatterij) | 14,7Vdc bij 25oC (Absorptie) 13,7Vdc bij 25oC (Float) |
| Laadstroom | 20Adc maximaal (3-staps karakteristiek) |
| Uitgangsspanning gebruikersgroepen | 12.5Vdc ± 5% |
| Uitgangsstroom gebruikersgroepen | 20Adc maximaal (verdeeld over 3 groepen) |
| Uitgangsvermogen totaal | 240W max. |
| 100 Hz uitgangsspanningsrimpel | ≤ 100mVpp bij 230Vac en max. uitgangsvermogen |
| Lekstroom (ontlaadstroom) | ≤ 0,5mA bij uitgeschakelde hoofdschakelaar Mascot 2590 |
| Bediening | Hoofdschakelaar op Mascot 2590 |
| Beveiligingen groepen | 25A-zekering op Mascot 2044 |
| Beveiliging netspanning | 4A (traag, intern Mascot 2044) |
| Beveiliging laadinrichting caravanbatterij | 25A-zekering op Mascot 2044 |
| Veiligheid | EN 60335-2-29 |
| EMC | EN 50081-1; EN 50082-1; EN 55014 |
| Koeling | Natuurlijke convectiekoeling |

Opmerkingen:

- * Zorg ervoor dat de CERS voldoende kan worden geventileerd om oververhitting te voorkomen.
- * Een defecte caravanaccu alsmede verkeerd aansluiten van de accu kan de interne zekering aanspreken. In dit geval dient de CERS bij de dealer ter reparatie te worden aangeboden.
- * De maximale laadstroom is afhankelijk van het totaal afgenomen vermogen van de CERS uitgangen. Pmax=240W.

7.4 Specificaties CERS 30

| Specificaties CERS 30D | |
|--|---|
| Ingangsspanningsbereik | 198-264Vac'' |
| Ingangsspanningsfrequentie | 45-66Hz |
| Ingangsstroom | ≤ 1.8A bij 230Vac in en 360W uit |
| Rendement | ≥ 84% bij 230Vac in en 360W uit |
| Uitgangsspanning laadcircuit (caravanbatterij) | 14,2Vdc bij 25oC (Absorptie) 13,2Vdc bij 25oC (Float) |
| Laadstroom | 20Adc maximaal met IUoUp-karakteristiek (3-staps karakteristiek) |
| Booster capaciteit | 8,5-14,2V / 6,0A max. laadstroom |
| Solar capaciteit | 110W / 6,0A max. laadstroom |
| Uitgangsspanning gebruikersgroepen | 12.5Vdc ± 5% |
| Uitgangsstroom gebruikersgroepen | 10Adc max. per groep |
| Uitgangsvermogen totaal | 360W max. |
| 100 Hz uitgangsspanningsrimpel | ≤ 100mVpp bij 230Vac en max. uitgangsvermogen |
| Lekstroom (ontlaadstroom) | ≤ 10mA |
| Bediening | Bedieningspaneel via een 4-aderige RJ-11 telefoonkabel |
| Beveiligingen groepen | 3 uitgangen: 10A via buck-converter |
| Beveiliging netspanning | 4A (traag) beveiligd tegen piekspanning |
| Beveiliging laadinrichting caravanbatterij | 40A-zekering Ompoolbeveiliging Het laadcircuit wordt uitgeschakeld bij een temperatuur van 50oC van de batterij; battery service led licht op Bij poolspanning lager dan 10.5 V wordt laadcircuit uitgeschakeld; battery service led licht op Resetmogelijkheid in geval van foutsituatie |
| Veiligheid | EN 60335-2-29 |
| EMC | EN 50081-1; EN 60555-2; EN 55022, class B; EN 50082-11; |
| Koeling | Natuurlijke convectiekoeling |

- Opmerkingen:
- * Zorg ervoor dat de CERS voldoende kan worden geventileerd om oververhitting te voorkomen.
 - * Een defecte caravanaccu alsmede verkeerd aansluiten van de accu kan de interne zekering aanspreken. In dit geval dient de CERS bij de dealer ter reparatie te worden aangeboden.
 - * De maximale laadstroom is afhankelijk van het totaal afgenomen vermogen van de CERS uitgangen. Pmax=360W.

7.5 Verkeersverlichting en permanente stroomdraad Cers en Koelkast 1 t/m 13

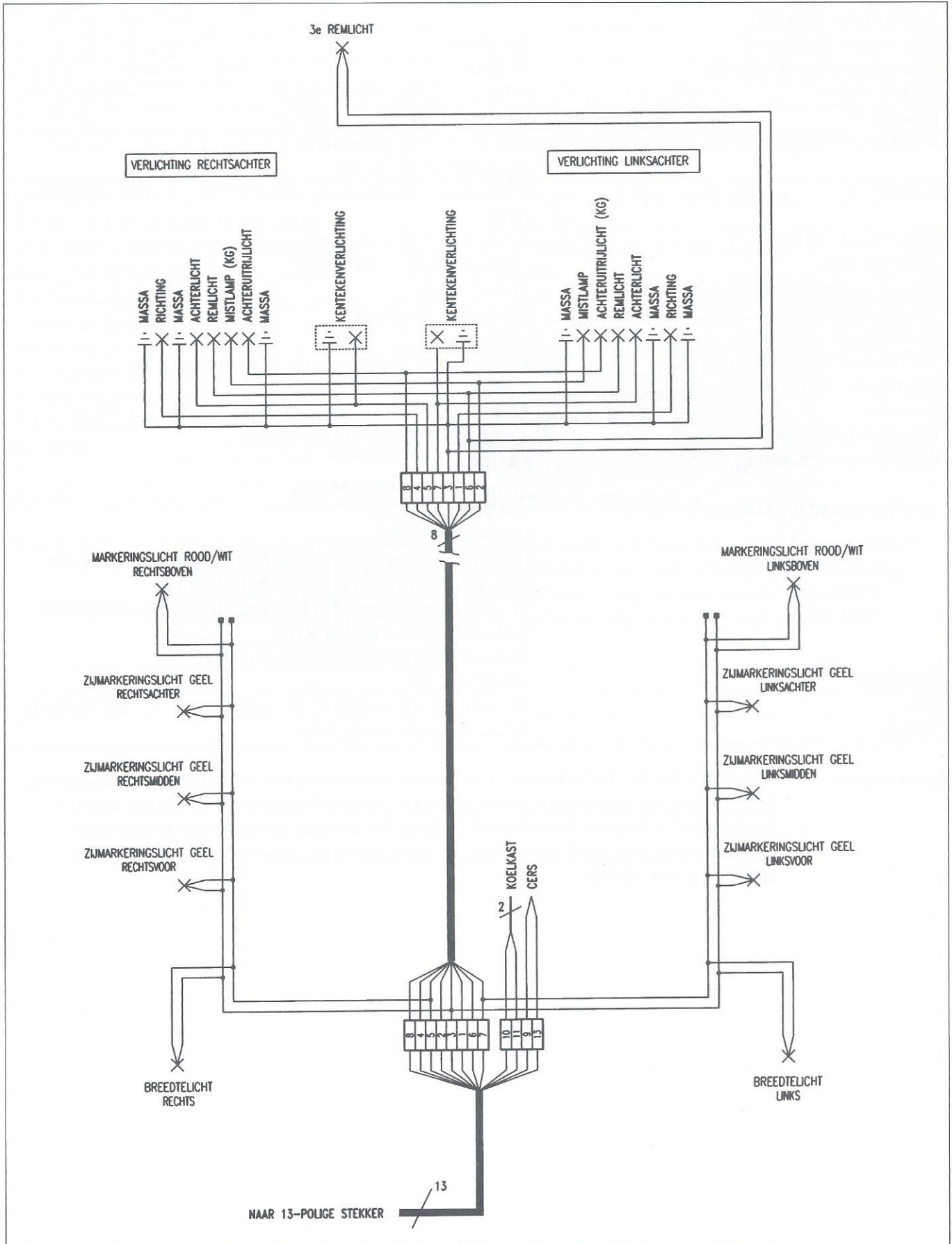

7.6 Aansluitschema tv-antenne

AANSLUITING TV-ANTENNE

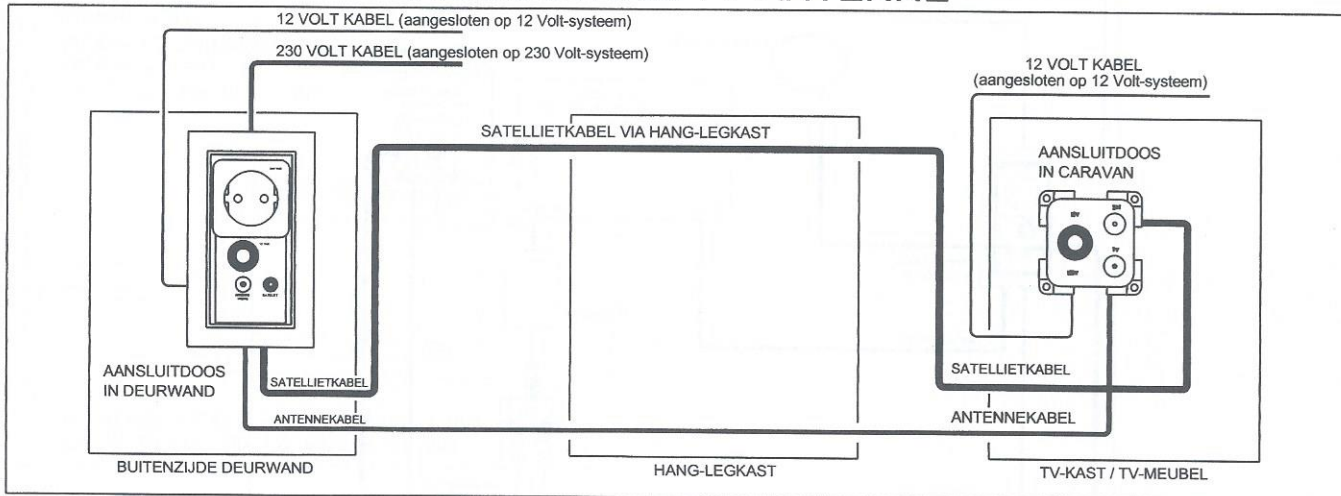

**MOGELIJKHEID AANSLUITING SATELLIETONTVANGER
SCHOTEL VIA HANGKAST-WCD * NIET STANDAARD
(montage door dealer)**

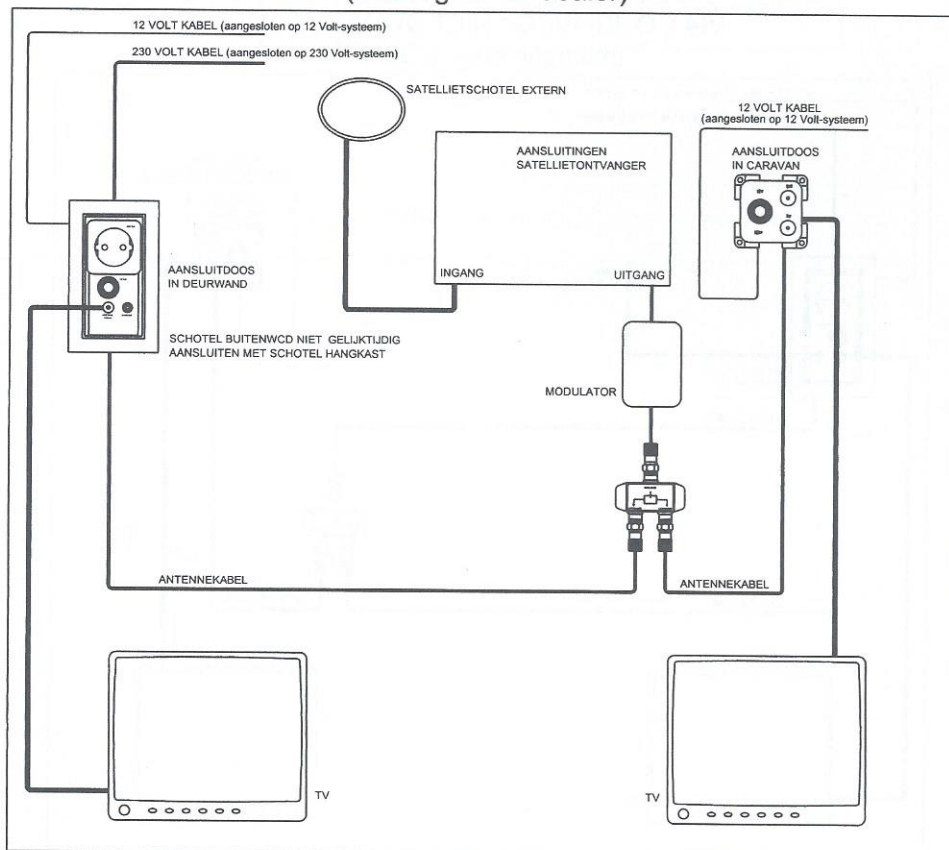

**MOGELIJKHEID AANSLUITING SATELLIETONTVANGER
SCHOTEL VIA COMBI-WCD * NIET STANDAARD
(montage door dealer)**

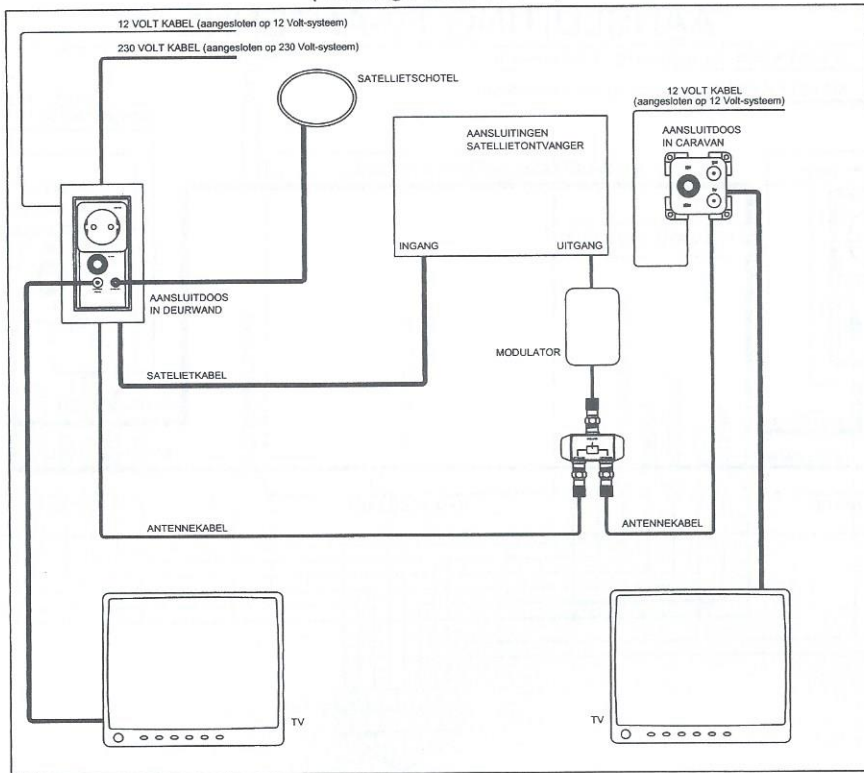

**MOGELIJKHEID AANSLUITING KABEL-TV CAMPING
VIA COMBI-WCD * NIET STANDAARD
(montage door dealer)**

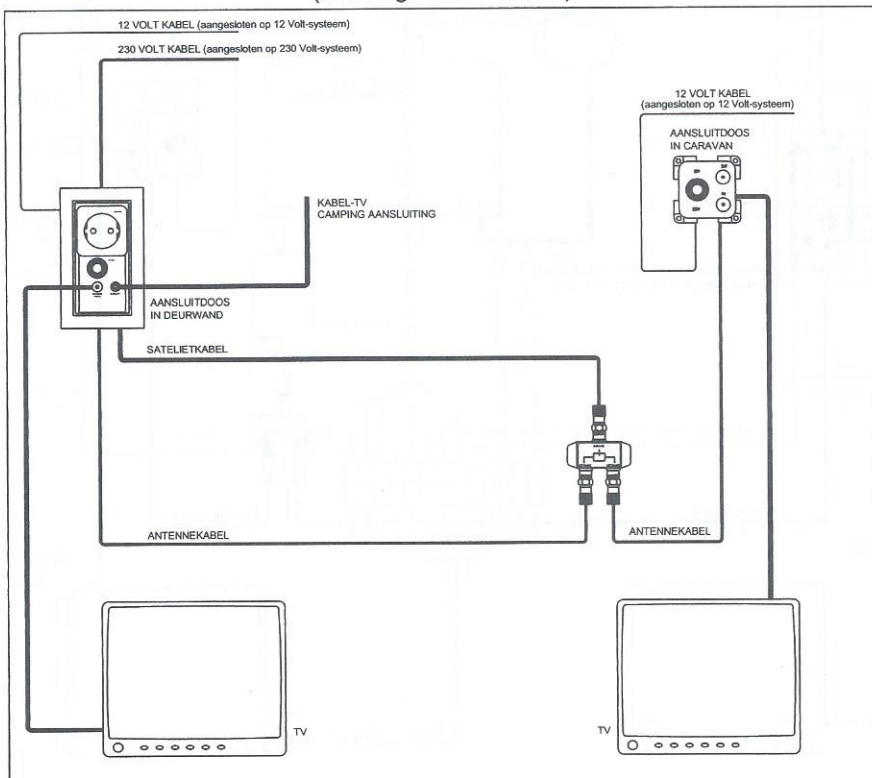

7.7 Aansluiting permanente stroomdraad en koelkast in auto

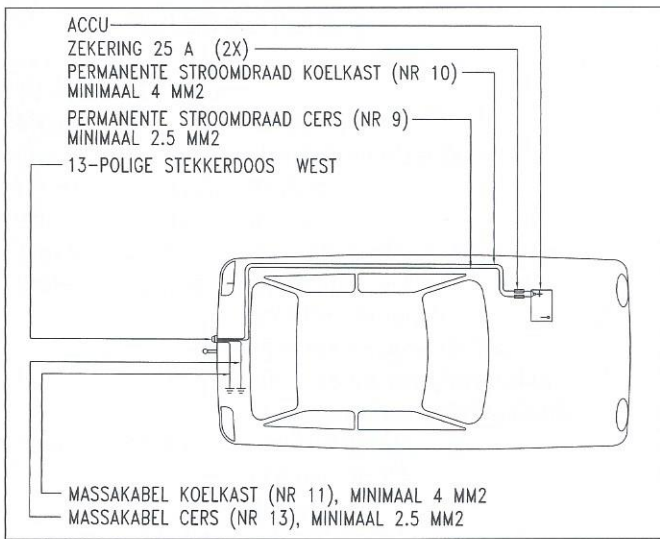

7.8 Schema vloerverwarming

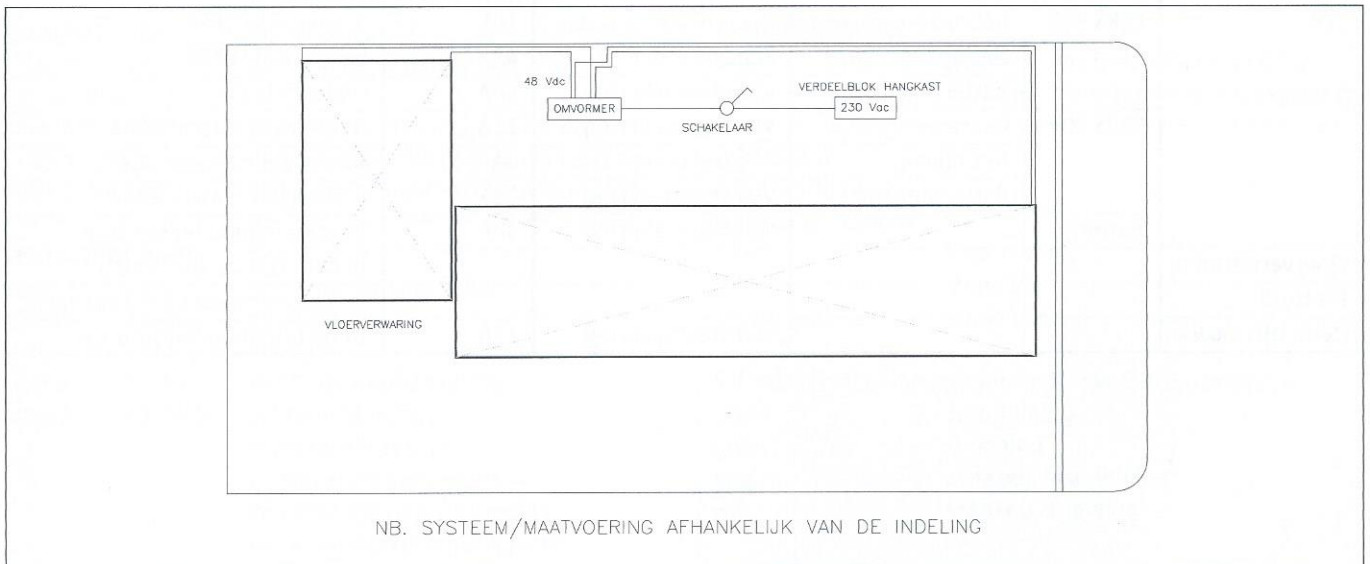

7.12 Overzicht lampen verkeersverlichting

| Verkeersverlichting | | | | |
|-----------------------------|----------|------|-------------|-----|
| Omschrijving | Sokkel | Watt | Caravantype | |
| | | | AAE | AGT |
| Achterlicht | BAY 15D | 21/5 | • | • |
| Remlicht | BAY 15D | 21/5 | • | • |
| Richtingaanwijzer | BA 15S | 21 | • | • |
| 3e remlicht | LED | | • | • |
| Mistlamp | BA 15S | 21 | • | • |
| Achteruitrijlicht | BA 15S | 21 | • | • |
| Nummerplaatverlichting | SV 8,5-8 | 5 | • | • |
| Zijmarkeringslicht rood/wit | C5W | 5 | • | • |
| Zijmarkeringslicht geel | LED | | • | • |
| Breedtelicht | SV8,5-8 | 5 | • | |
| Breedtelicht | W3W | 3 | | • |

7.13 Overzicht toegepaste zekeringen

| | | | | | |
|---------------------|-----------------|------------------|------------------------|--------------------------------------|----------------------------|
| 230V | Aardlekautomaat | | | C 10A/30mA | Hanglegkast |
| 12V | CERS 30D | Gebuikersgroepen | Buckconverter (autom.) | 10A | Binnenzijde CERS |
| | | Netingang | Zandzekering | 4A | Binnenzijde CERS |
| | | Batterijingang | Vlaksteekzekering | 40A | Onderzijde Cers |
| | CERS 20M | Gebuikersgroepen | Vlaksteekzekering | 25A | Buitenzijde Mascot 2044 |
| | | Netingang | Zandzekering | 4A | Binnenzijde Mascot 2044 |
| | | Batterijingang | Vlaksteekzekering | 25A | Buitenzijde Mascot 2044 |
| | Batterij | | Vlaksteekzekering | 40A | In zekeringhouder tpv accu |
| Vloerverwarming | | | | In behuizing transformator | |
| Thetford | | | | In zekeringhouder t.p.v. schakelunit | |
| Elektr. lattenbodem | | | Vlaksteekzekering | 15A | In zekeringhouder tpv accu |

7.14 Kleurcodering draadbomen Avento caravans - 12 volt

Verkeersverlichting

| <p>13-ADERIGE KABEL</p> <table style="width: 100%; border-collapse: collapse;"> <thead> <tr> <th style="text-align: left;">kleur</th> <th style="text-align: left;">functie</th> </tr> </thead> <tbody> <tr> <td>geel (1/L)</td> <td>richtingaanwijzer links</td> </tr> <tr> <td>blauw (2/54G)</td> <td>mistlamp</td> </tr> <tr> <td>wit (3/31)</td> <td>massa</td> </tr> <tr> <td>groen (4/R)</td> <td>richtingaanwijzer rechts</td> </tr> <tr> <td>bruin (5/58R)</td> <td>achterlicht rechts breedtelicht rechts zijmarkering geel rechts zijmarkering rood/wit rechts nummerplaatverlichting rechts</td> </tr> <tr> <td>rood (6/54)</td> <td>remlicht links remlicht rechts 3e remlicht</td> </tr> <tr> <td>zwart (7/58L)</td> <td>achterlicht links breedtelicht links zijmarkering geel links zijmarkering rood/wit links nummerplaatverlichting links</td> </tr> <tr> <td>geel/wit (8)</td> <td>achteruitrijlicht</td> </tr> <tr> <td>blauw (9)</td> <td>permanente stroomdraad CERS</td> </tr> <tr> <td>grijs/rood (12)</td> <td></td> </tr> <tr> <td>blauw/wit (10)</td> <td>permanente stroomdraad koelkast</td> </tr> <tr> <td>wit/blauw (11)</td> <td>massa permanente stroomdraad koelkast</td> </tr> <tr> <td>wit/groen (13)</td> <td>massa permanente stroomdraad CERS</td> </tr> </tbody> </table> | kleur | functie | geel (1/L) | richtingaanwijzer links | blauw (2/54G) | mistlamp | wit (3/31) | massa | groen (4/R) | richtingaanwijzer rechts | bruin (5/58R) | achterlicht rechts breedtelicht rechts zijmarkering geel rechts zijmarkering rood/wit rechts nummerplaatverlichting rechts | rood (6/54) | remlicht links remlicht rechts 3e remlicht | zwart (7/58L) | achterlicht links breedtelicht links zijmarkering geel links zijmarkering rood/wit links nummerplaatverlichting links | geel/wit (8) | achteruitrijlicht | blauw (9) | permanente stroomdraad CERS | grijs/rood (12) | | blauw/wit (10) | permanente stroomdraad koelkast | wit/blauw (11) | massa permanente stroomdraad koelkast | wit/groen (13) | massa permanente stroomdraad CERS | <p>MONTAGEDRAAD</p> <table style="width: 100%; border-collapse: collapse;"> <tbody> <tr> <td>geel (1/L)</td> <td>richtingaanwijzer links</td> </tr> <tr> <td>blauw (2/54G)</td> <td>mistlamp</td> </tr> <tr> <td>wit (3/31)</td> <td>massa</td> </tr> <tr> <td>groen (4/R)</td> <td>richtingaanwijzer rechts</td> </tr> <tr> <td>bruin (5/58R)</td> <td>achterlicht rechts breedtelicht rechts zijmarkering geel rechts zijmarkering rood/wit rechts nummerplaatverlichting rechts</td> </tr> <tr> <td>rood (6/54)</td> <td>remlicht links remlicht rechts 3e remlicht</td> </tr> <tr> <td>zwart (7/58L)</td> <td>achterlicht links breedtelicht links zijmarkering geel links zijmarkering rood/wit links nummerplaatverlichting links</td> </tr> </tbody> </table> <hr/> <p>2-ADERIGE KABEL</p> <table style="width: 100%; border-collapse: collapse;"> <tbody> <tr> <td>bruin (10)</td> <td>permanente stroomdraad koelkast</td> </tr> <tr> <td>blauw (11)</td> <td>massa permanente stroomdraad koelkast</td> </tr> </tbody> </table> <hr/> <p>INTERIEUR</p> <p><i>230V INSTALLATIE</i></p> <p>Wandcontactdozen</p> <table style="width: 100%; border-collapse: collapse;"> <tbody> <tr> <td>bruin</td> <td>fase-leiding</td> </tr> <tr> <td>blauw</td> <td>0-leiding</td> </tr> <tr> <td>groen/geel</td> <td>aardeleiding</td> </tr> </tbody> </table> <p>Schakelaar vloerverwarming en Truma Therme boiler</p> <table style="width: 100%; border-collapse: collapse;"> <tbody> <tr> <td>bruin</td> <td>fase-leiding</td> </tr> <tr> <td>groen</td> <td>0-leiding</td> </tr> <tr> <td>geel</td> <td>schakel/ fase-leiding</td> </tr> <tr> <td>wit</td> <td>schakel/ 0-leiding</td> </tr> </tbody> </table> <p><i>12V INSTALLATIE</i></p> <table style="width: 100%; border-collapse: collapse;"> <tbody> <tr> <td>rood/geel (+)</td> <td>autoaccu – permanente stroomdraad</td> </tr> <tr> <td>oranje (+)</td> <td>groep 1</td> </tr> <tr> <td>blauw (+)</td> <td>groep 2</td> </tr> <tr> <td>rood (+)</td> <td>groep 3</td> </tr> <tr> <td>zwart/wit (-)</td> <td>massa algemeen</td> </tr> <tr> <td>bruin/rood (+)</td> <td>zonnepaneel</td> </tr> <tr> <td>rood (1 mm²) (+)</td> <td>verbruiker</td> </tr> <tr> <td>zwart (1 mm²) (-)</td> <td>massa verbruiker</td> </tr> <tr> <td>rood (4 mm²) (+)</td> <td>caravanbatterij</td> </tr> <tr> <td>zwart (4 mm²) (-)</td> <td>massa caravanbatterij</td> </tr> </tbody> </table> <p>Alde-installatie</p> <table style="width: 100%; border-collapse: collapse;"> <tbody> <tr> <td>rood (+)</td> <td>circulatiepomp (hangkast)</td> </tr> <tr> <td>zwart (-)</td> <td>circulatiepomp (hangkast)</td> </tr> </tbody> </table> | geel (1/L) | richtingaanwijzer links | blauw (2/54G) | mistlamp | wit (3/31) | massa | groen (4/R) | richtingaanwijzer rechts | bruin (5/58R) | achterlicht rechts breedtelicht rechts zijmarkering geel rechts zijmarkering rood/wit rechts nummerplaatverlichting rechts | rood (6/54) | remlicht links remlicht rechts 3e remlicht | zwart (7/58L) | achterlicht links breedtelicht links zijmarkering geel links zijmarkering rood/wit links nummerplaatverlichting links | bruin (10) | permanente stroomdraad koelkast | blauw (11) | massa permanente stroomdraad koelkast | bruin | fase-leiding | blauw | 0-leiding | groen/geel | aardeleiding | bruin | fase-leiding | groen | 0-leiding | geel | schakel/ fase-leiding | wit | schakel/ 0-leiding | rood/geel (+) | autoaccu – permanente stroomdraad | oranje (+) | groep 1 | blauw (+) | groep 2 | rood (+) | groep 3 | zwart/wit (-) | massa algemeen | bruin/rood (+) | zonnepaneel | rood (1 mm ²) (+) | verbruiker | zwart (1 mm ²) (-) | massa verbruiker | rood (4 mm ²) (+) | caravanbatterij | zwart (4 mm ²) (-) | massa caravanbatterij | rood (+) | circulatiepomp (hangkast) | zwart (-) | circulatiepomp (hangkast) |
|--|--|---------|------------|-------------------------|---------------|----------|------------|-------|-------------|--------------------------|---------------|--|-------------|--|---------------|---|--------------|-------------------|-----------|-----------------------------|-----------------|--|----------------|---------------------------------|----------------|---------------------------------------|----------------|-----------------------------------|---|------------|-------------------------|---------------|----------|------------|-------|-------------|--------------------------|---------------|--|-------------|--|---------------|---|------------|---------------------------------|------------|---------------------------------------|-------|--------------|-------|-----------|------------|--------------|-------|--------------|-------|-----------|------|-----------------------|-----|--------------------|---------------|-----------------------------------|------------|---------|-----------|---------|----------|---------|---------------|----------------|----------------|-------------|-------------------------------|------------|--------------------------------|------------------|-------------------------------|-----------------|--------------------------------|-----------------------|----------|---------------------------|-----------|---------------------------|
| kleur | functie | | | | | | | | | | | | | | | | | | | | | | | | | | | | | | | | | | | | | | | | | | | | | | | | | | | | | | | | | | | | | | | | | | | | | | | | | | | | | | | | | | | | |
| geel (1/L) | richtingaanwijzer links | | | | | | | | | | | | | | | | | | | | | | | | | | | | | | | | | | | | | | | | | | | | | | | | | | | | | | | | | | | | | | | | | | | | | | | | | | | | | | | | | | | | |
| blauw (2/54G) | mistlamp | | | | | | | | | | | | | | | | | | | | | | | | | | | | | | | | | | | | | | | | | | | | | | | | | | | | | | | | | | | | | | | | | | | | | | | | | | | | | | | | | | | | |
| wit (3/31) | massa | | | | | | | | | | | | | | | | | | | | | | | | | | | | | | | | | | | | | | | | | | | | | | | | | | | | | | | | | | | | | | | | | | | | | | | | | | | | | | | | | | | | |
| groen (4/R) | richtingaanwijzer rechts | | | | | | | | | | | | | | | | | | | | | | | | | | | | | | | | | | | | | | | | | | | | | | | | | | | | | | | | | | | | | | | | | | | | | | | | | | | | | | | | | | | | |
| bruin (5/58R) | achterlicht rechts breedtelicht rechts zijmarkering geel rechts zijmarkering rood/wit rechts nummerplaatverlichting rechts | | | | | | | | | | | | | | | | | | | | | | | | | | | | | | | | | | | | | | | | | | | | | | | | | | | | | | | | | | | | | | | | | | | | | | | | | | | | | | | | | | | | |
| rood (6/54) | remlicht links remlicht rechts 3e remlicht | | | | | | | | | | | | | | | | | | | | | | | | | | | | | | | | | | | | | | | | | | | | | | | | | | | | | | | | | | | | | | | | | | | | | | | | | | | | | | | | | | | | |
| zwart (7/58L) | achterlicht links breedtelicht links zijmarkering geel links zijmarkering rood/wit links nummerplaatverlichting links | | | | | | | | | | | | | | | | | | | | | | | | | | | | | | | | | | | | | | | | | | | | | | | | | | | | | | | | | | | | | | | | | | | | | | | | | | | | | | | | | | | | |
| geel/wit (8) | achteruitrijlicht | | | | | | | | | | | | | | | | | | | | | | | | | | | | | | | | | | | | | | | | | | | | | | | | | | | | | | | | | | | | | | | | | | | | | | | | | | | | | | | | | | | | |
| blauw (9) | permanente stroomdraad CERS | | | | | | | | | | | | | | | | | | | | | | | | | | | | | | | | | | | | | | | | | | | | | | | | | | | | | | | | | | | | | | | | | | | | | | | | | | | | | | | | | | | | |
| grijs/rood (12) | | | | | | | | | | | | | | | | | | | | | | | | | | | | | | | | | | | | | | | | | | | | | | | | | | | | | | | | | | | | | | | | | | | | | | | | | | | | | | | | | | | | | |
| blauw/wit (10) | permanente stroomdraad koelkast | | | | | | | | | | | | | | | | | | | | | | | | | | | | | | | | | | | | | | | | | | | | | | | | | | | | | | | | | | | | | | | | | | | | | | | | | | | | | | | | | | | | |
| wit/blauw (11) | massa permanente stroomdraad koelkast | | | | | | | | | | | | | | | | | | | | | | | | | | | | | | | | | | | | | | | | | | | | | | | | | | | | | | | | | | | | | | | | | | | | | | | | | | | | | | | | | | | | |
| wit/groen (13) | massa permanente stroomdraad CERS | | | | | | | | | | | | | | | | | | | | | | | | | | | | | | | | | | | | | | | | | | | | | | | | | | | | | | | | | | | | | | | | | | | | | | | | | | | | | | | | | | | | |
| geel (1/L) | richtingaanwijzer links | | | | | | | | | | | | | | | | | | | | | | | | | | | | | | | | | | | | | | | | | | | | | | | | | | | | | | | | | | | | | | | | | | | | | | | | | | | | | | | | | | | | |
| blauw (2/54G) | mistlamp | | | | | | | | | | | | | | | | | | | | | | | | | | | | | | | | | | | | | | | | | | | | | | | | | | | | | | | | | | | | | | | | | | | | | | | | | | | | | | | | | | | | |
| wit (3/31) | massa | | | | | | | | | | | | | | | | | | | | | | | | | | | | | | | | | | | | | | | | | | | | | | | | | | | | | | | | | | | | | | | | | | | | | | | | | | | | | | | | | | | | |
| groen (4/R) | richtingaanwijzer rechts | | | | | | | | | | | | | | | | | | | | | | | | | | | | | | | | | | | | | | | | | | | | | | | | | | | | | | | | | | | | | | | | | | | | | | | | | | | | | | | | | | | | |
| bruin (5/58R) | achterlicht rechts breedtelicht rechts zijmarkering geel rechts zijmarkering rood/wit rechts nummerplaatverlichting rechts | | | | | | | | | | | | | | | | | | | | | | | | | | | | | | | | | | | | | | | | | | | | | | | | | | | | | | | | | | | | | | | | | | | | | | | | | | | | | | | | | | | | |
| rood (6/54) | remlicht links remlicht rechts 3e remlicht | | | | | | | | | | | | | | | | | | | | | | | | | | | | | | | | | | | | | | | | | | | | | | | | | | | | | | | | | | | | | | | | | | | | | | | | | | | | | | | | | | | | |
| zwart (7/58L) | achterlicht links breedtelicht links zijmarkering geel links zijmarkering rood/wit links nummerplaatverlichting links | | | | | | | | | | | | | | | | | | | | | | | | | | | | | | | | | | | | | | | | | | | | | | | | | | | | | | | | | | | | | | | | | | | | | | | | | | | | | | | | | | | | |
| bruin (10) | permanente stroomdraad koelkast | | | | | | | | | | | | | | | | | | | | | | | | | | | | | | | | | | | | | | | | | | | | | | | | | | | | | | | | | | | | | | | | | | | | | | | | | | | | | | | | | | | | |
| blauw (11) | massa permanente stroomdraad koelkast | | | | | | | | | | | | | | | | | | | | | | | | | | | | | | | | | | | | | | | | | | | | | | | | | | | | | | | | | | | | | | | | | | | | | | | | | | | | | | | | | | | | |
| bruin | fase-leiding | | | | | | | | | | | | | | | | | | | | | | | | | | | | | | | | | | | | | | | | | | | | | | | | | | | | | | | | | | | | | | | | | | | | | | | | | | | | | | | | | | | | |
| blauw | 0-leiding | | | | | | | | | | | | | | | | | | | | | | | | | | | | | | | | | | | | | | | | | | | | | | | | | | | | | | | | | | | | | | | | | | | | | | | | | | | | | | | | | | | | |
| groen/geel | aardeleiding | | | | | | | | | | | | | | | | | | | | | | | | | | | | | | | | | | | | | | | | | | | | | | | | | | | | | | | | | | | | | | | | | | | | | | | | | | | | | | | | | | | | |
| bruin | fase-leiding | | | | | | | | | | | | | | | | | | | | | | | | | | | | | | | | | | | | | | | | | | | | | | | | | | | | | | | | | | | | | | | | | | | | | | | | | | | | | | | | | | | | |
| groen | 0-leiding | | | | | | | | | | | | | | | | | | | | | | | | | | | | | | | | | | | | | | | | | | | | | | | | | | | | | | | | | | | | | | | | | | | | | | | | | | | | | | | | | | | | |
| geel | schakel/ fase-leiding | | | | | | | | | | | | | | | | | | | | | | | | | | | | | | | | | | | | | | | | | | | | | | | | | | | | | | | | | | | | | | | | | | | | | | | | | | | | | | | | | | | | |
| wit | schakel/ 0-leiding | | | | | | | | | | | | | | | | | | | | | | | | | | | | | | | | | | | | | | | | | | | | | | | | | | | | | | | | | | | | | | | | | | | | | | | | | | | | | | | | | | | | |
| rood/geel (+) | autoaccu – permanente stroomdraad | | | | | | | | | | | | | | | | | | | | | | | | | | | | | | | | | | | | | | | | | | | | | | | | | | | | | | | | | | | | | | | | | | | | | | | | | | | | | | | | | | | | |
| oranje (+) | groep 1 | | | | | | | | | | | | | | | | | | | | | | | | | | | | | | | | | | | | | | | | | | | | | | | | | | | | | | | | | | | | | | | | | | | | | | | | | | | | | | | | | | | | |
| blauw (+) | groep 2 | | | | | | | | | | | | | | | | | | | | | | | | | | | | | | | | | | | | | | | | | | | | | | | | | | | | | | | | | | | | | | | | | | | | | | | | | | | | | | | | | | | | |
| rood (+) | groep 3 | | | | | | | | | | | | | | | | | | | | | | | | | | | | | | | | | | | | | | | | | | | | | | | | | | | | | | | | | | | | | | | | | | | | | | | | | | | | | | | | | | | | |
| zwart/wit (-) | massa algemeen | | | | | | | | | | | | | | | | | | | | | | | | | | | | | | | | | | | | | | | | | | | | | | | | | | | | | | | | | | | | | | | | | | | | | | | | | | | | | | | | | | | | |
| bruin/rood (+) | zonnepaneel | | | | | | | | | | | | | | | | | | | | | | | | | | | | | | | | | | | | | | | | | | | | | | | | | | | | | | | | | | | | | | | | | | | | | | | | | | | | | | | | | | | | |
| rood (1 mm ²) (+) | verbruiker | | | | | | | | | | | | | | | | | | | | | | | | | | | | | | | | | | | | | | | | | | | | | | | | | | | | | | | | | | | | | | | | | | | | | | | | | | | | | | | | | | | | |
| zwart (1 mm ²) (-) | massa verbruiker | | | | | | | | | | | | | | | | | | | | | | | | | | | | | | | | | | | | | | | | | | | | | | | | | | | | | | | | | | | | | | | | | | | | | | | | | | | | | | | | | | | | |
| rood (4 mm ²) (+) | caravanbatterij | | | | | | | | | | | | | | | | | | | | | | | | | | | | | | | | | | | | | | | | | | | | | | | | | | | | | | | | | | | | | | | | | | | | | | | | | | | | | | | | | | | | |
| zwart (4 mm ²) (-) | massa caravanbatterij | | | | | | | | | | | | | | | | | | | | | | | | | | | | | | | | | | | | | | | | | | | | | | | | | | | | | | | | | | | | | | | | | | | | | | | | | | | | | | | | | | | | |
| rood (+) | circulatiepomp (hangkast) | | | | | | | | | | | | | | | | | | | | | | | | | | | | | | | | | | | | | | | | | | | | | | | | | | | | | | | | | | | | | | | | | | | | | | | | | | | | | | | | | | | | |
| zwart (-) | circulatiepomp (hangkast) | | | | | | | | | | | | | | | | | | | | | | | | | | | | | | | | | | | | | | | | | | | | | | | | | | | | | | | | | | | | | | | | | | | | | | | | | | | | | | | | | | | | |

8. CHASSISTYPES - ALKO

| | AT 365 | AT 395 | AT 445 | AT 465 | AGT 430 | AGT 470 | AGT 500 |
|-----------------|--------------------------|--------------------------|--------------------------|--------------------------|--------------------------|--------------------------|--------------------------|
| Astype | SI-N12 | SI-N12 | SI-N12-3 | SI-N14-1 | SI-N14-1 | SI-N14-3 | SI-N14-3 |
| Wielrem | 2051/A | 2051/A | 2051/Ab | 2051/Ab | 2051/Ab | 2361 | 2361 |
| Banden | 195/65 R15 reinforced | 195/65 R15 reinforced | 195/65 R15 commercial | 205/65 R15 commercial | 205/65 R15 reinforced | 205/65 R15 commercial | 205/65 R15 commercial |
| Velgen-alu | 6Jx15 | 6Jx15 | 6Jx15 | 6Jx15 | 6Jx15 | 6Jx15 | 6Jx15 |
| Wiellagers 2051 | 39/72-37 | 39/72-37 | 39/72-37 | 39/72-37 | 39/72-37 | ----- | ----- |
| Wiellagers 2361 | ----- | ----- | ----- | ----- | ----- | 42/82-42 | 42/82-42 |

9. GEWICHTEN (in kg)

| TYPE | LEEGGEWICHT STANDAARD/COMFORT | TOELAATBARE MAXIMALE MASSA | LAADVERMOGEN STANDAARD/COMFORT |
|-----------|----------------------------------|-------------------------------|-----------------------------------|
| AT365TCB | 920/950 | 1200 | 280/250 |
| AT365TLH | 920/950 | 1200 | 280/250 |
| AT395TCB | 985/1015 | 1300 | 315/285 |
| AT395TLH | 985/1015 | 1300 | 315/285 |
| AT445TF | 1015/1045 | 1360 | 345/315 |
| AT465TF | 1135/1165 | 1500 | 365/335 |
| AGT430TLH | 1165 | 1500 | 335 |
| AGT430TF | 1165 | 1500 | 335 |
| AGT470TF | 1230 | 1600 | 370 |
| AGT470TCB | 1280 | 1600 | 320 |
| AGT500TF | 1300 | 1700 | 400 |

Een afwijking van 5% voor het leeggewicht kan optreden.